

**Modular Cooking Range Line
EVO900 Gas Cylindrical Boiling Pan
100lt indirect heat, automatic refill**

ITEM # _____

MODEL # _____

NAME # _____

SIS # _____

AIA # _____

**392101 (Z9BSGHIPFR)**

100-lt gas boiling pan with pressure switch, indirect heating, automatic water filling in the jacket

Short Form Specification

Item No. _____

Suitable for natural gas or LPG. To be installed on cantilever systems but also incorporates fixing points for bridging. Robust burners in stainless steel with flame failure device and protected pilot light. Automatic water refill through electrovalve. Exterior panels of unit in stainless steel with Scotch Brite finish. Double jacketed lid made in 2mm thick AISI 316 stainless steel. Pressed well with rounded edges manufactured from AISI 316 stainless steel. Right-angled side edges to allow flush-fitting junction between units. Includes safety valve to control working pressure. Temperature limiter for power regulation allowing precise temperature cooking.

Main Features

- Round kettle is suitable to cook, sauté or poach all kinds of produce.
- Produce is uniformly heated in the base and side walls of the kettle by an indirect heating system that uses integrally generated saturated steam at a temperature of 110° C in the jacket.
- External valve allows to manually evacuate excess air accumulated in the jacket during heating phase.
- Appliance is IPX5 water resistance certified.
- Manometer allows to correctly control the functioning of the pan.
- Thermostatic temperature control.
- Energy regulation through a control knob.
- Safety thermostat protects against low water level.
- Safety valve avoids overpressure of the steam in the jacket.
- No overshooting of cooking temperatures, fast reaction.
- Large capacity food tap enables safe and effortless discharging of contents.
- Ergonomic: the depth of the vessel facilitates stirring the food, also the most delicate food.
- Discharge tube and tap are very easy to clean from outside.
- Electrovalve automatically refills vessel with water.
- Smooth large surfaces, easy access for cleaning.
- The special design of the control knob system guarantees against water infiltration.
- Minimum load for correct functioning is 20 liters.

Construction

- Pressed cooking vessel in 316L AISI Stainless steel.
- Robust burners in stainless steel with flame failure device, protected pilot light and optimized combustion.
- All exterior panels in Stainless Steel with Scotch Brite finishing.
- Model has right-angled side edges to allow flush fitting joints between units, eliminating gaps and possible dirt traps.
- Usable capacity of the well 85 liters.

Sustainability

- Kettle shall be double jacketed including high quality thermal insulation of the pan, saving energy and keeping ambient temperature low.
- Firmly fitting cover to reduce cooking time and save energy costs.
- Closed heating system – no waste of energy.
- Pressure switch control monitors energy and water consumption.

APPROVAL: _____

Included Accessories

- 1 of Water additive against corrosion for indirect boiling pans PNC 927222

Optional Accessories

- Junction sealing kit PNC 206086
- Draught diverter, 150 mm diameter PNC 206132
- Matching ring for flue condenser, 150 mm diameter PNC 206133
- 4 wheels, 2 swivelling with brake (EVO700/900). It is mandatory to install with base supports for feet/wheels. PNC 206135
- Flanged feet kit PNC 206136
- Frontal kicking strip for concrete installation, 800 mm PNC 206148
- Frontal kicking strip for concrete installation, 1000 mm PNC 206150
- Frontal kicking strip for concrete installation, 1200 mm PNC 206151
- Frontal kicking strip for concrete installation, 1600 mm PNC 206152
- Frontal kicking strip, 800 mm PNC 206176
- Frontal kicking strip, 1000 mm PNC 206177
- Frontal kicking strip, 1200 mm PNC 206178
- Frontal kicking strip, 1600 mm PNC 206179
- Pair of side kicking strips PNC 206180
- 2 panels for service duct (single installation) PNC 206181
- 2 panels for service duct (back to back installation) PNC 206202
- 4 feet for concrete installation (not for 900 line freestanding grill) PNC 206210
- Flue condenser for 1 module, 150 mm diameter PNC 206246
- Kit for automatic depressuring of the jacket for 100/150lt indirect and autoclave boiling pans PNC 206279
- Chimney upstand, 800 mm PNC 206304
- 2 side covering panels, height 700 mm, depth 900 mm PNC 206335
- Base support for feet or wheels - 800mm (EVO700/900) PNC 206367
- Base support for feet or wheels - 1200mm (EVO700/EVO900) PNC 206368
- Base support for feet or wheels - 1600mm (EVO700/900) PNC 206369
- Base support for feet or wheels - 2000mm (EVO700/900) PNC 206370
- Rear paneling - 800mm (EVO700/900) PNC 206374
- Rear paneling - 1000mm (EVO700/900) PNC 206375
- Rear paneling - 1200mm (EVO700/900) PNC 206376
- Chimney grid net, 400mm PNC 206400
- Kit G.25.3 (NI) gas nozzles for 900 boiling pans PNC 206463

- Trolley with lifting and removable tank PNC 922403
- 2-section universal basket for 100lt boiling pans PNC 925018
- Measuring rod for 100 l boiling pan PNC 927001
- Water additive against corrosion for indirect boiling pans PNC 927222
- Pressure regulator for gas units PNC 927225

Front

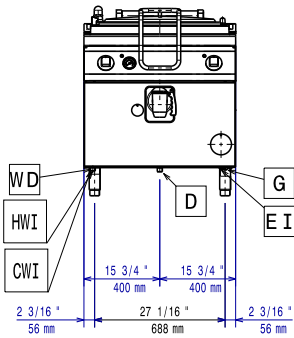

Side

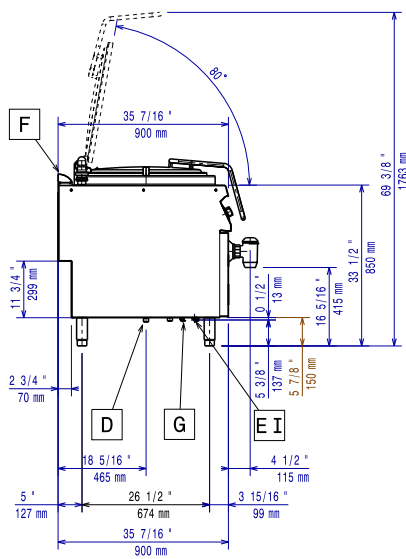

- CW11** = Cold Water inlet 1 (cleaning)
- HWI** = Hot water inlet
- D** = Drain
- EI** = Electrical inlet (power)
- G** = Gas connection

Top

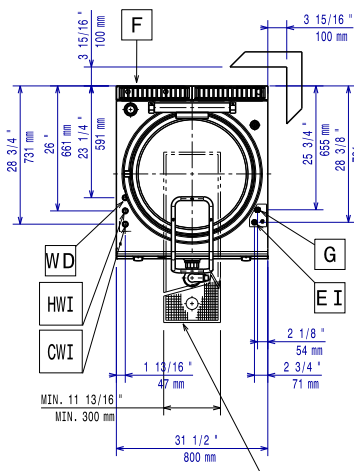

Electric

Supply voltage:
392101 (Z9BSGHIPFR) 220-230 V/1 ph/50 Hz
Total Watts: 0.1 kW

Gas

Gas Power: 21 kW
Standard gas delivery: Natural Gas G20 (20mbar)
Gas Type Option: LPG; Natural Gas
Gas Inlet: 1/2"

Key Information:

Pan useful capacity: 98 lt
Vessel (round) diameter: 600 mm
Net weight: 135 kg
Shipping weight: 134 kg
Shipping height: 1240 mm
Shipping width: 1110 mm
Shipping depth: 860 mm
Shipping volume: 1.18 m³

No clearance needed on rear sides of unit if wall is of non combustible type. If wall is combustible, minimum 50 mm wall clearance should be maintained.

Certification group: N9PIG